DIRECT-DETECTION SINGLE-SIDEBAND SYSTEMS: PERFORMANCE COMPARISON AND PRACTICAL IMPLEMENTATION PENALTIES

DARIO PILORI AND ROBERTO GAUDINO

DEPT. OF ELECTRONICS AND TELECOMMUNICATIONS (DET), POLITECNICO DI TORINO, 10129 TORINO, ITALY

- Introduction to single-sideband (SSB) systems
- Practical implementation penalties of an SSB transmitter
 - Using DMT modulation

INTRODUCTION TO SINGLE-SIDEBAND SYSTEMS



WHICH MODULATION FORMAT FOR DATA-CENTER?

<http://imagebank.osa.org/getImage.xqy?img=LmZ1bGwsam9jbi0xMC03LUlyNS1nMDAy&article=joen-10-7-B25-g002>

Source: R. Nagarajan et al., J. Opt. Commun. Netw. 10, B25-B36 (2018)



Main characteristics for this scenario

- Standard single-mode fiber (SSMF) up to 100km
- C-band (EDFAs required at TX and RX)
 - Dispersion must be compensated
- High spectral efficiency not required
- Low cost and power consumption

Inphi and Microsoft: PAM-4 (current),
PM-16QAM (future)

Coherent or direct detection?

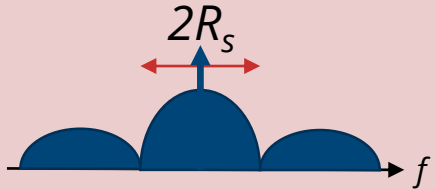
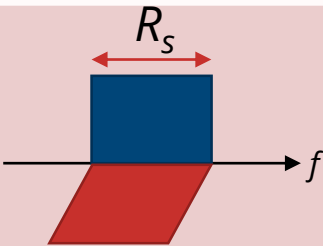
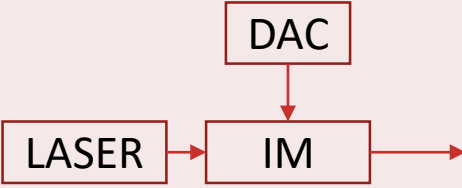
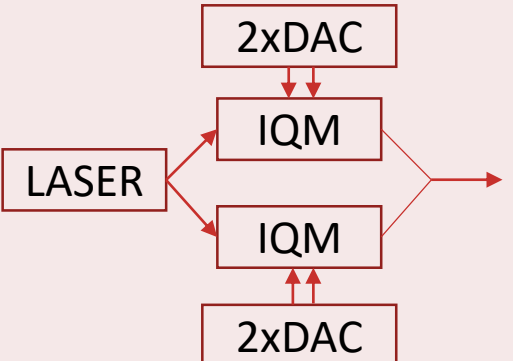
COHERENT OR DIRECT DETECTION?

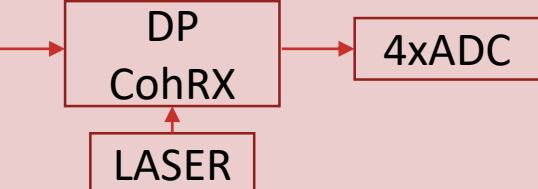
	PAM-4 (direct detection)	16-QAM (coherent detection)
<i>Spectral efficiency</i>	 <p>A spectral diagram showing three blue pulses on a frequency axis f. The total width of the pulses is labeled $2R_s$.</p>	 <p>A spectral diagram showing a single blue rectangular pulse on a frequency axis f. The width of the pulse is labeled R_s. A red shaded area is shown below the pulse, representing a tilted spectrum.</p>
<i>TX architecture</i>	 <p>A block diagram showing a LASER block connected to an IM (Intensity Modulator) block, which is connected to a DAC (Digital-to-Analog Converter) block.</p>	 <p>A block diagram showing a LASER block connected to two IQM (In-Phase/Quadrature Modulator) blocks. The top IQM is connected to a 2xDAC block. The bottom IQM is connected to another 2xDAC block. The outputs of both IQM blocks are combined.</p>
<i>RX architecture</i>	 <p>A block diagram showing an input signal entering a PD (Photodetector) block, which is connected to an ADC (Analog-to-Digital Converter) block.</p>	 <p>A block diagram showing an input signal entering a DP CohRX (Differential Coherent Receiver) block, which is connected to a 4xADC (4x Analog-to-Digital Converter) block. A LASER block is also connected to the DP CohRX block.</p>
<i>Dispersion compensation</i>	Optical	Electrical

THE SEARCH FOR COMPROMISE

1. Direct detection
2. Higher spectral efficiency
3. Electronic dispersion compensation

SINGLE-SIDEBAND SELF-COHERENT TRANSMITTER

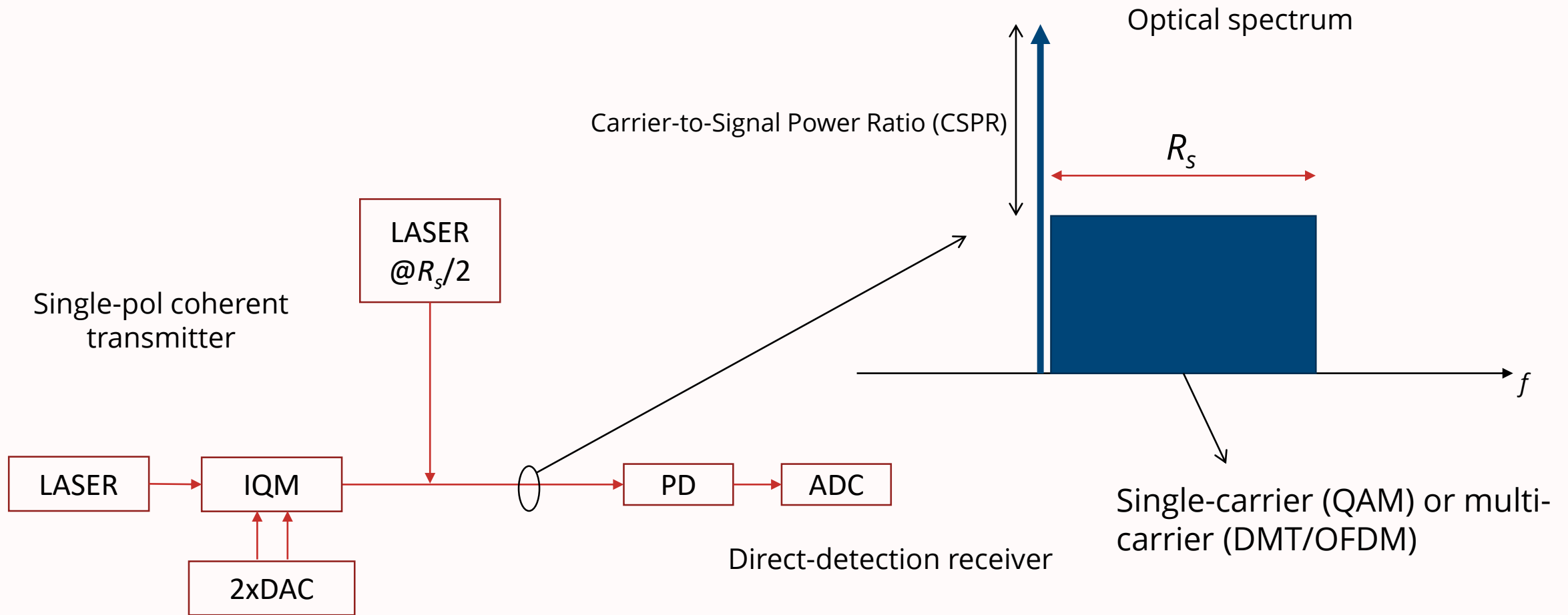

SINGLE-SIDEBAND SELF-COHERENT RECEIVER

$$\left| x(t) + c \cdot e^{-j2\pi t R_s/2} \right|^2 = |x(t)|^2 + c^2 + 2c \cdot \Re \left\{ x(t) e^{j2\pi t R_s/2} \right\}$$

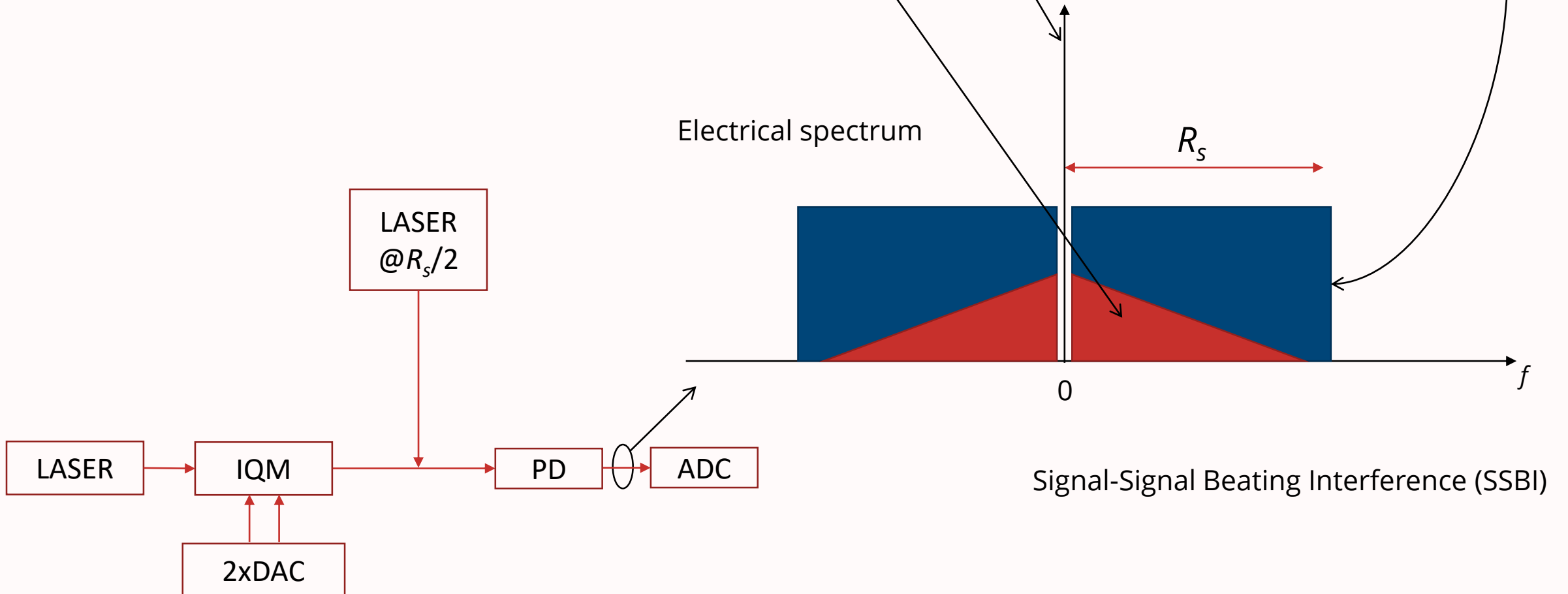

SSB TRANSMISSION: PROS AND CONS

1. Direct detection ✓
 2. Higher spectral efficiency ✓
 3. Electronic dispersion compensation ✓
-
1. Complex transmitter structure ✗
 2. High receiver analog bandwidth ✗
 3. Reduced OSNR sensitivity ✗

EXAMPLE: DISCRETE-MULTITONE WITHOUT OPTICAL DISPERSION COMPENSATION

Source: T. Takahara et al., Proc. OFC 2014, M2I.1

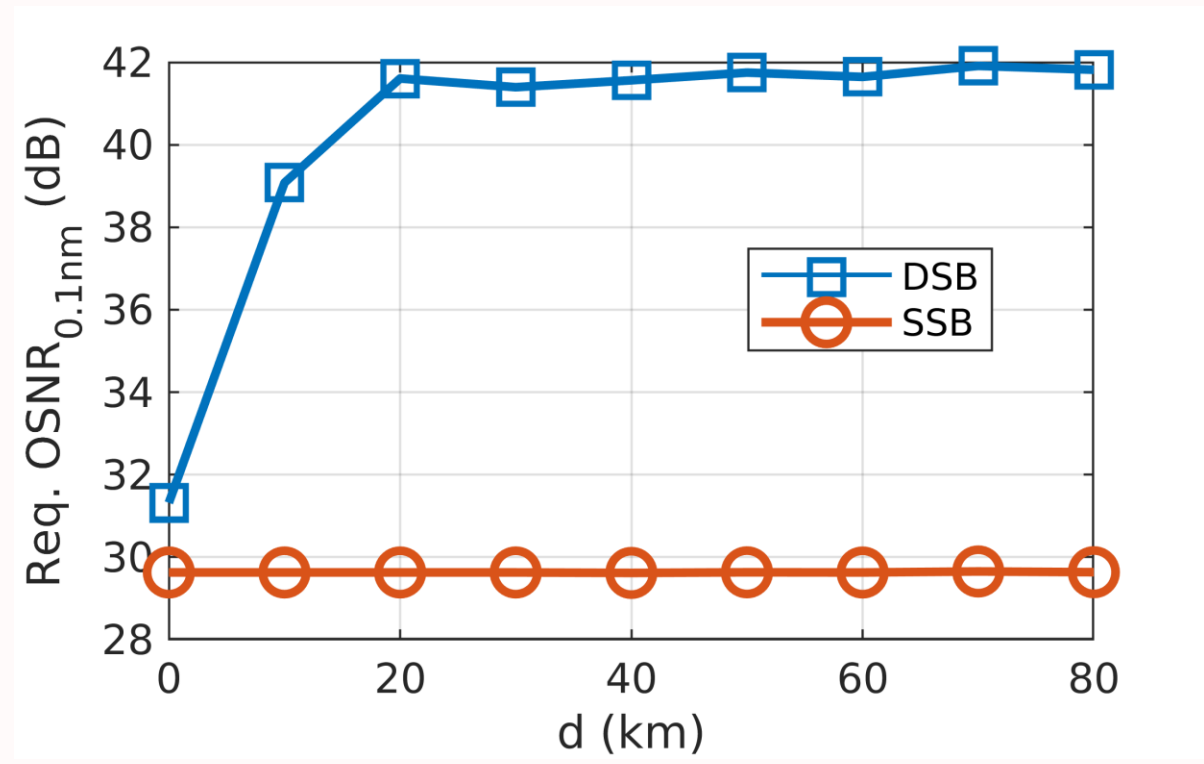
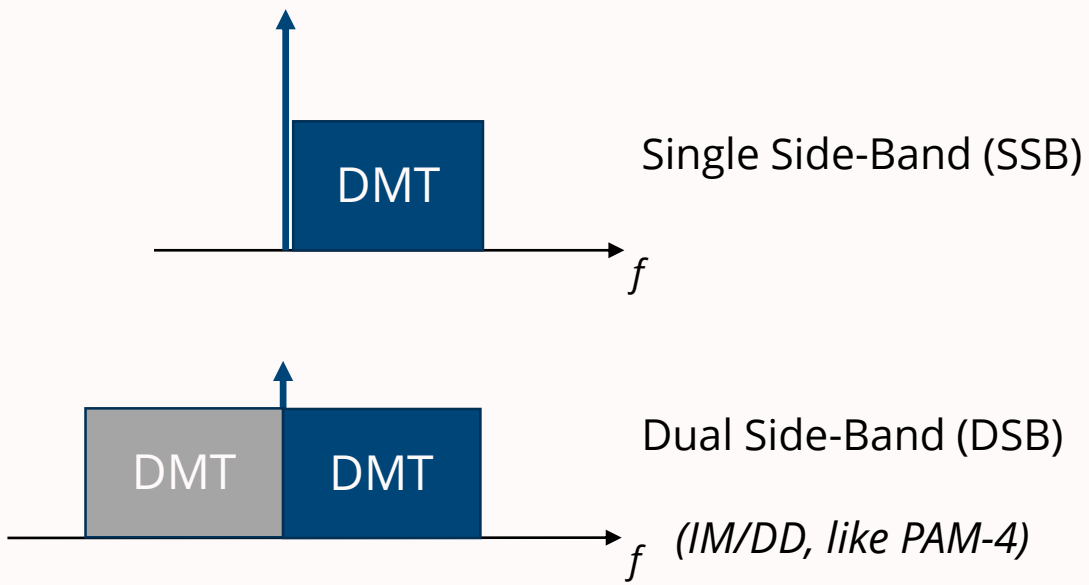

SIGNAL-SIGNAL BEATING INTERFERENCE

SSBI mitigation algorithms^{1,2}

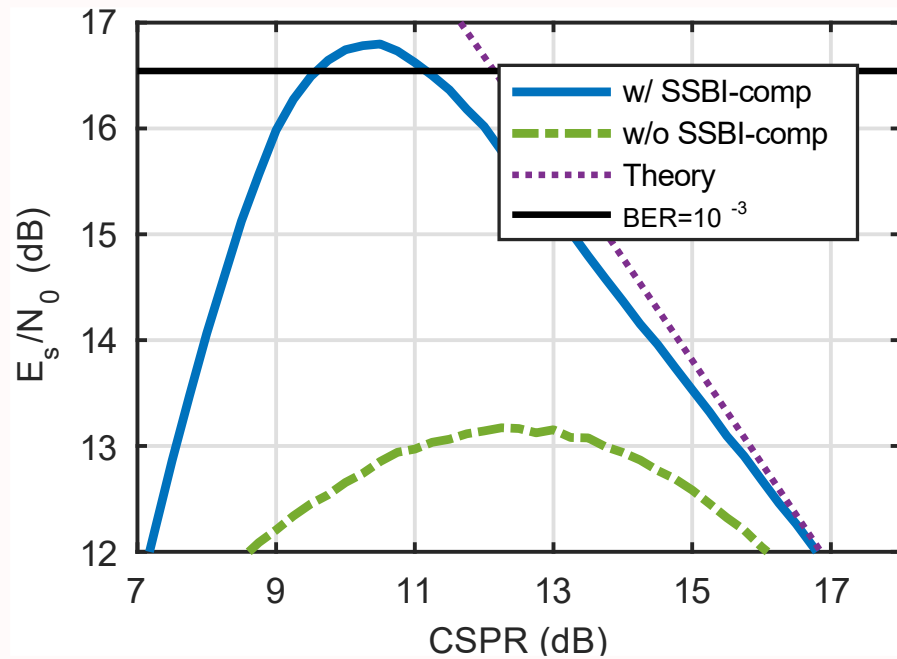
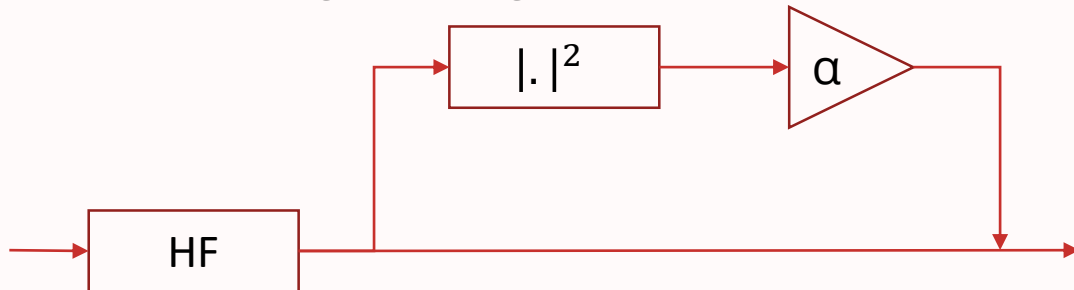

100 Gb/s DMT, B2B OSNR=30 dB

Kramers-Kronig receiver³

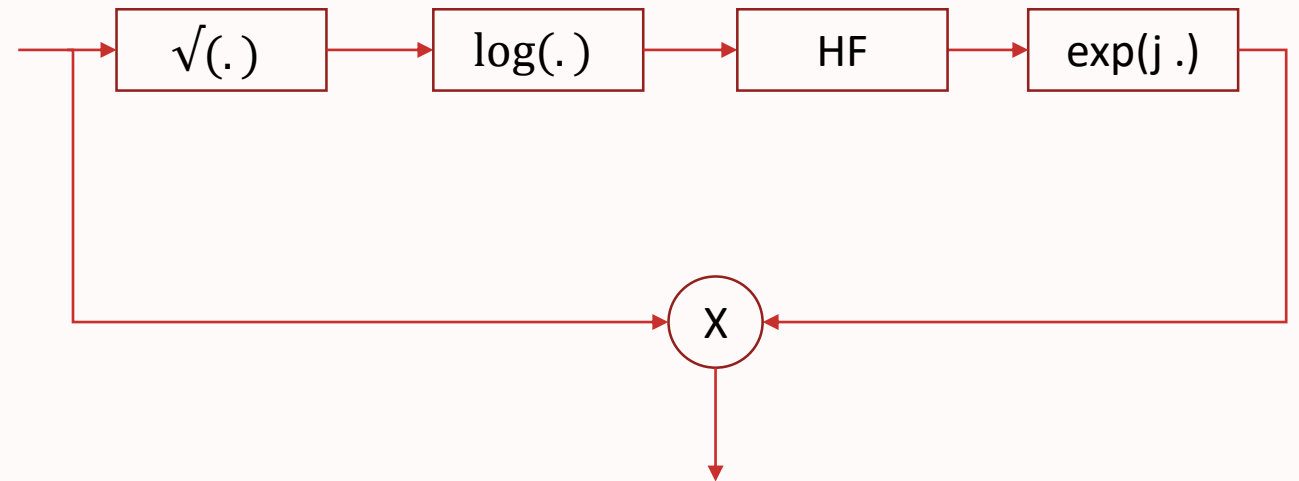

- Higher performances with lower CSPRs ✓
- Higher receiver complexity ✗

PRACTICAL IMPLEMENTATION PENALTIES



IMPLEMENTATION OF A DMT-BASED SINGLE SIDE-BAND TRANSMITTER

SSB TRANSMITTER ARCHITECTURES

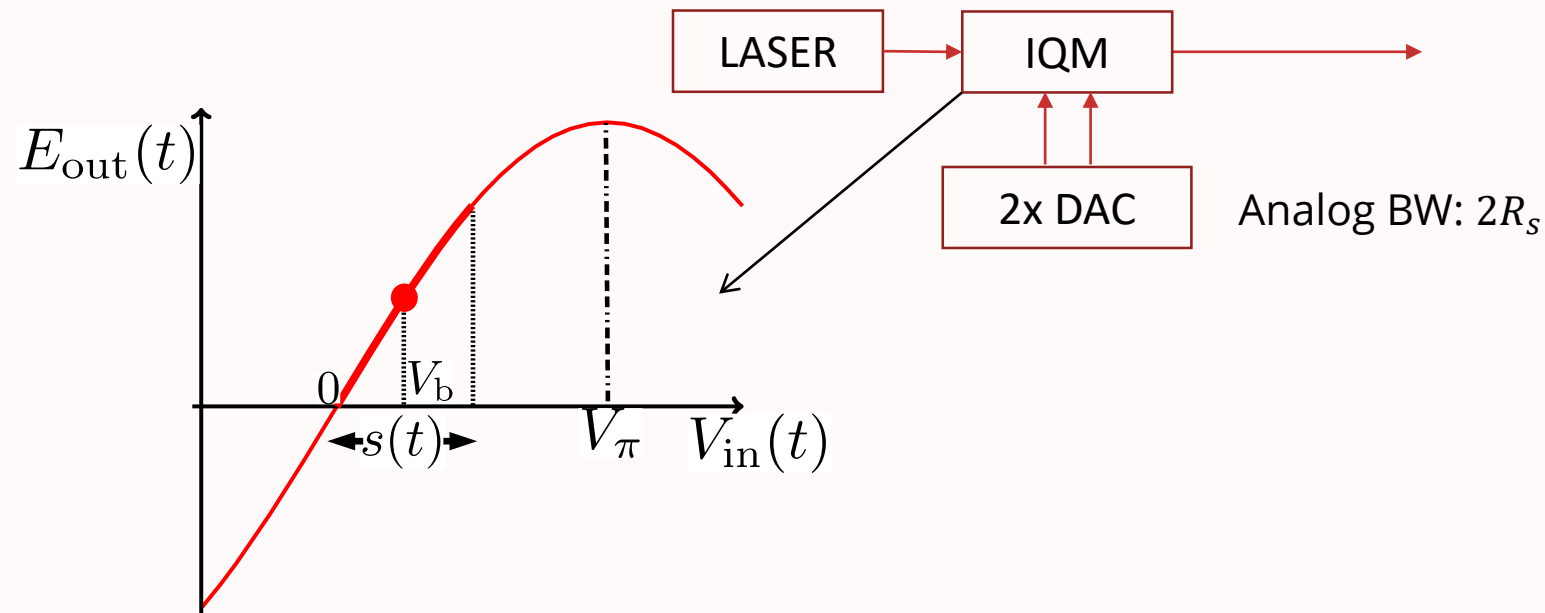
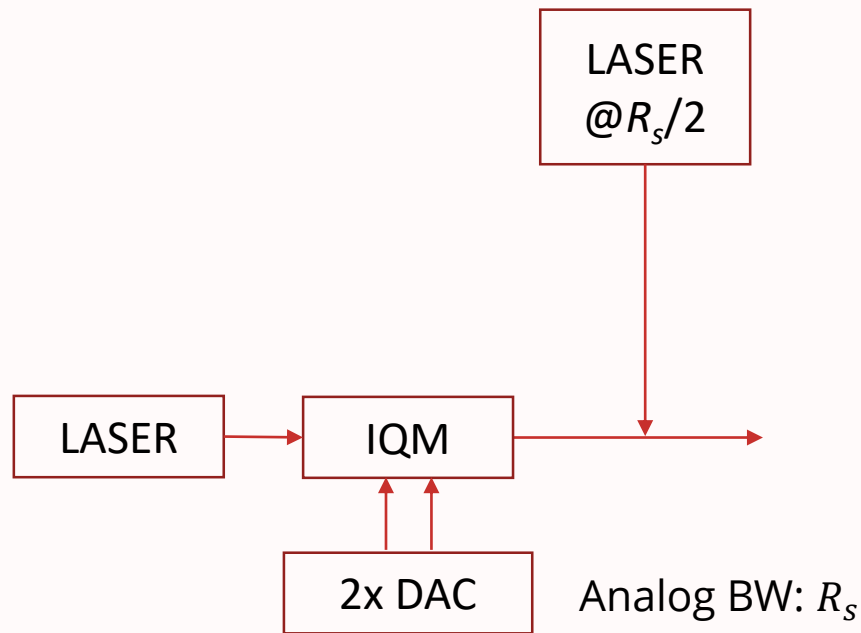

- Two lasers ✗
- Control of frequency difference ✗
- Receiver phase recovery ✗

- One laser ✓
- No receiver phase recovery ✓
- Twice DAC bandwidth ✗
- Signal distortions at high CSRR ✗

EVALUATION OF CARRIER-TO-SIGNAL POWER RATIO

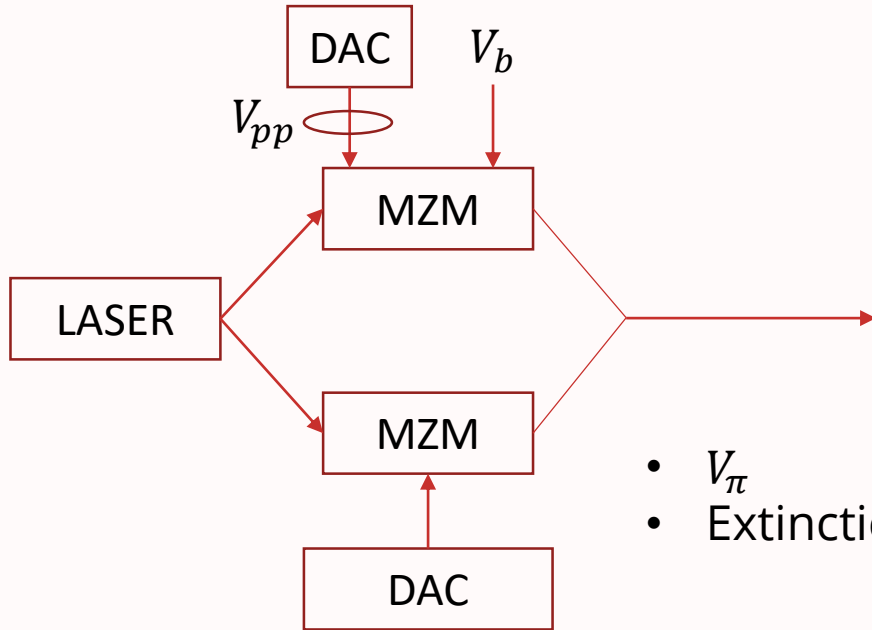

- V_{π}
- Extinction ratio (ER)

$$\text{CSPR} \approx \frac{2e^{-\frac{\pi^2 \sigma^2}{V_{\pi}^2}} \left[\sin^2 \left(\frac{\pi V_b}{2V_{\pi}} \right) - \frac{2 \sin \left(\frac{\pi V_b}{2V_{\pi}} \right)}{\text{ER}} + \frac{1 + \cos^2 \left(\frac{\pi V_b}{2V_{\pi}} \right)}{\text{ER}^2} \right]}{\left[1 - e^{-\frac{\pi^2 \sigma^2}{2V_{\pi}^2}} \right] \left[2 + \cos \left(\frac{\pi V_b}{V_{\pi}} \right) e^{-\frac{\pi^2 \sigma^2}{2V_{\pi}^2}} + e^{-\frac{\pi^2 \sigma^2}{2V_{\pi}^2}} \right]}$$

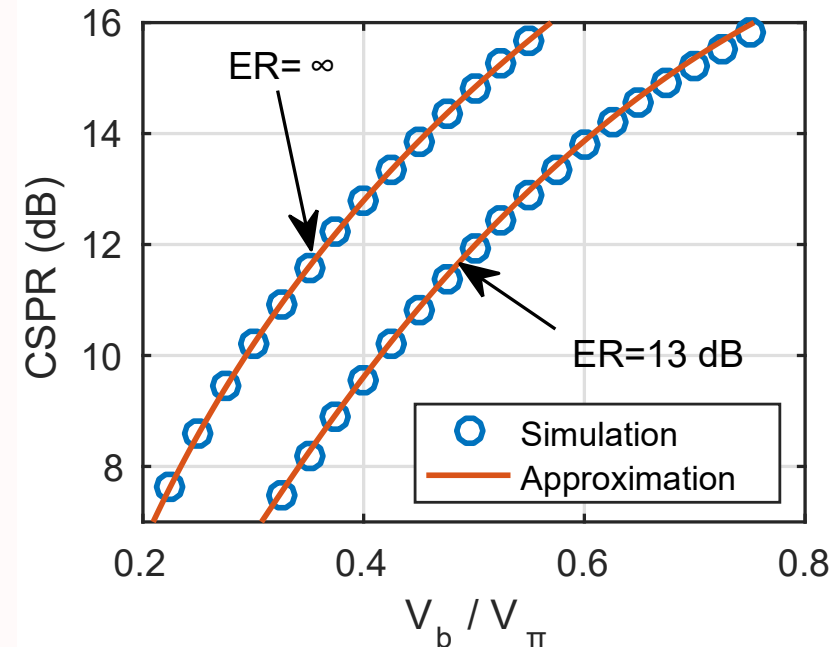

APPLICATION EXAMPLE TO DISCRETE-MULTITONE (DMT)

Source: T. Takahara et al., Proc. OFC 2014, M2I.1

Parameter	Value
FFT size	1024
Bitrate	120 Gbit/s
DAC sampling rate	64 GS/s
BER threshold	10^{-3}
DAC 3-dB bandwidth	13 GHz
DAC resolution	6 bit

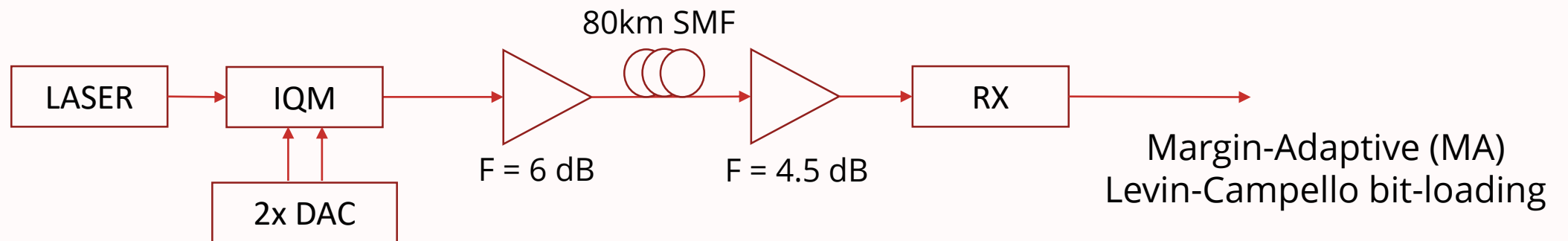

IDEAL (INFINITE EXTINCTION RATIO) MODULATOR

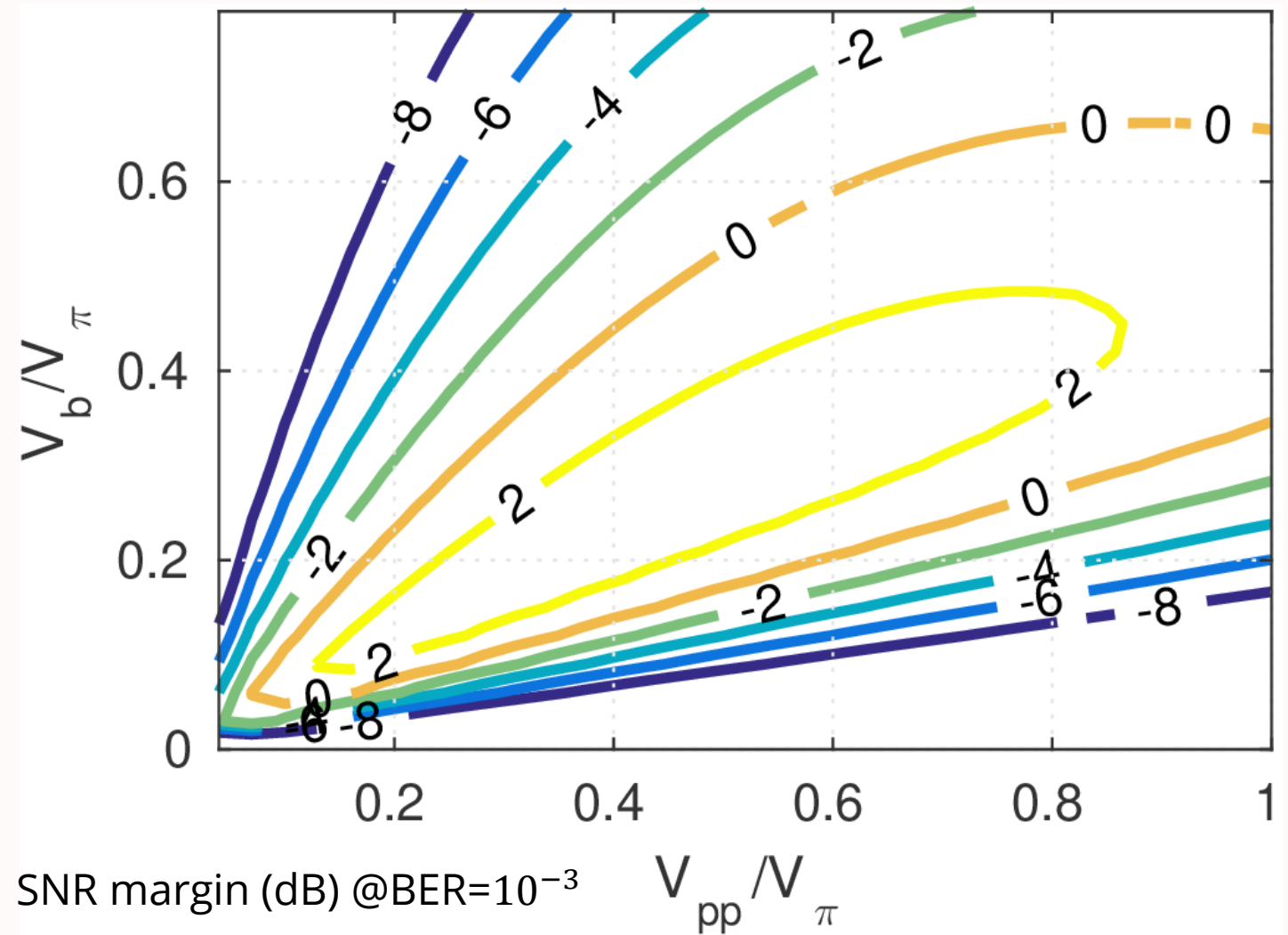
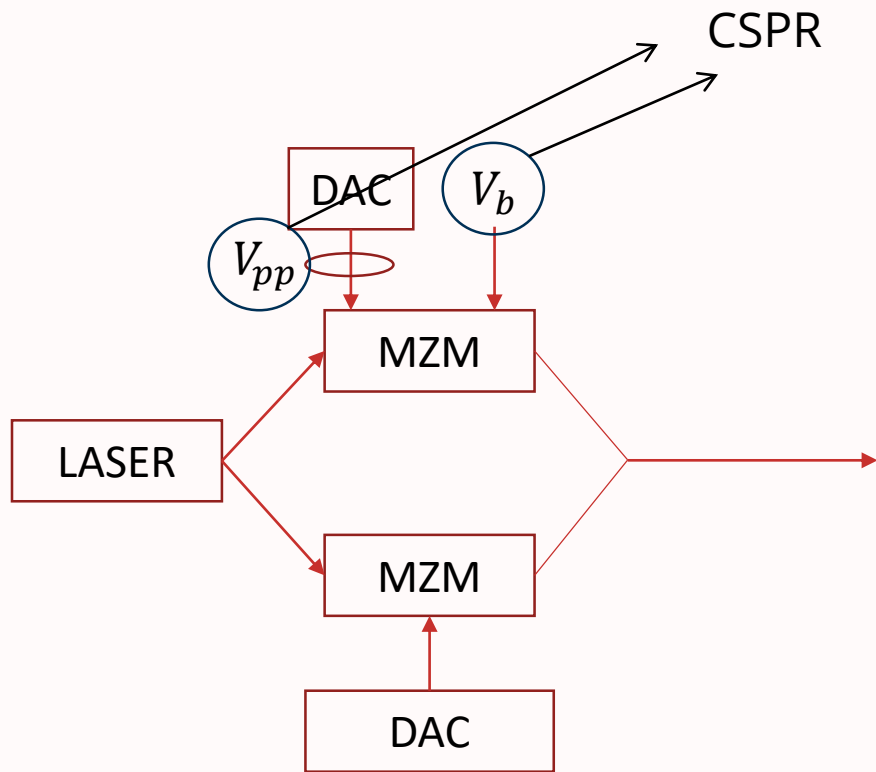

CONCLUSIONS AND KEY TAKE-AWAYS

- Single-sideband self-coherent systems are a possible compromise between coherent and direct-detection for DCI
- Transmitter structure is the most critical part of these systems
- With proper use of a Mach-Zehnder modulator, transmitter structure can be simplified

THANK YOU FOR YOUR ATTENTION!

Acknowledgements:

- This work is carried out in the PhotoNext initiative at Politecnico di Torino <http://www.photonext.polito.it/>
- The work was partially sponsored by Cisco Photonics
- Simulations were performed using the OptSim software by Synopsys

PHOTONEXT



SYNOPSYS®
Silicon to Software™



THANK YOU

DARIO.PILORI@POLITO.IT
